



---

---

# ESC User Manual

MODEL NAME : DR651B00(48V)

Ver.1.0

---



# Contents

1. Introduction .....	3
2. Safety Precautions .....	3
2.1. Precautions for Use .....	3
2.2. Disposal Precautions .....	5
2.3. Storage and Transportation Precautions .....	5
3. Warranty .....	5
4. Typical Characteristics .....	5
4.1. Absolute Maximum Ratings .....	5
4.2. Recommended Operating Conditions .....	6
4.3. DC Electrical Characteristics .....	6
4.4. A/D Converter Characteristics .....	7
4.5. Protection Functions .....	7
5. System Overview .....	9
5.1. ESC Connection Diagram (PWM Control) .....	9
5.2. ESC Connection Diagram (CAN Control) .....	10
5.3. Control Board Overview .....	10
5.4. Three-Phase Output Board Overview .....	10
5.5. Additional Information on PWM Signal .....	11
5.6. Input Capacitor Capacitance .....	11
6. Interface Assignment .....	11
6.1. External Interface Assignment .....	11
7. Power Cable Assignment .....	12
7.1. Three-Phase Output Board Lead Wire Assignment .....	12
8. Dimensional Drawing .....	12
8.1. Overall External Dimensions of the Completed Product .....	12





## 1. Introduction





This manual is a hardware instruction manual for the speed controller module (hereinafter referred to as ESC) that controls a three-phase brushless motor.

## 2. Safety Precautions

Please use this ESC at your own discretion. Our company is not responsible for any harm or damage caused by its use. The following information is important to prevent harm to you or others and to prevent damage to property, and to ensure safe and correct use of the product. Please read this manual carefully before use and follow the instructions.

Symbol	Explanation
 <b>WARNING</b>	Indicates that the user may be killed or seriously injured if handled incorrectly.
 <b>CAUTION</b>	Indicates that the user may suffer minor injuries or that property damage may occur if handled incorrectly.
<b>NOTICE</b>	Indicates a note.

### 2.1. Precautions for Use

Precautions	
 <b>WARNING</b>	Do not store or use this product in an area where explosive gases or dust may be generated. This may cause an explosion.
 <b>WARNING</b>	Do not use this product in a radiation environment. This product is not radiation-resistant.
 <b>CAUTION</b>	Contacting the power terminals with your fingers or metal objects may result in electric shock or burns due to abnormal heat generation. Avoid unnecessary contact with the power terminals.
 <b>CAUTION</b>	If the unit becomes abnormally hot, stop using it immediately. After stopping, confirm that the abnormal heat has subsided. There is a risk of burns.
 <b>CAUTION</b>	Be careful not to touch the pin header during installation. There is a risk of injury.
<b>NOTICE</b>	Do not disassemble, repair, or modify this unit. This may cause malfunctions or damage.
<b>NOTICE</b>	Please ensure that there are no foreign objects inside the connector when connecting. This may cause a poor connection.



<b>NOTICE</b>	Please be careful not to overtighten the screws. This may cause damage.
<b>NOTICE</b>	Do not apply excessive force to the connector. This may cause damage.
<b>NOTICE</b>	Please ensure that there is sufficient slack in the wiring when connecting. This may cause damage.
<b>NOTICE</b>	If you come into contact with any metal parts and experience any discomfort, stop using the product immediately and consult a medical professional.
<b>NOTICE</b>	Be careful not to allow oil, solvents, or other substances to come into contact with the product. This may cause the housing to deform or crack.
<b>NOTICE</b>	If the product becomes dirty, please be careful to wipe it clean without applying excessive force. Excessive cleaning may cause damage or discoloration of the housing. It is recommended to clean the product when it becomes dirty.
<b>NOTICE</b>	Do not handle the ESC by the cable only.
<b>NOTICE</b>	Do not insert or remove the lead wires while the product is powered.
<b>NOTICE</b>	Do not drop or strike the ESC forcefully. Even if there is no initial malfunction, we cannot guarantee the product warranty.
<b>NOTICE</b>	Please confirm the suitability for actual use in a driver-mounted state by yourself.
<b>NOTICE</b>	Beware of corrosive gases. This may cause rusting of metal parts and chemical effects on grease.
<b>NOTICE</b>	We do not guarantee the quality of the product after disassembly and reassembly.
<b>NOTICE</b>	Operators who handle the ESC directly and equipment that comes into contact with the ESC should take measures to prevent static electricity and leakage.
<b>NOTICE</b>	We cannot guarantee any patent issues other than the ESC. Please conduct a thorough investigation and use the product at your own risk.
<b>NOTICE</b>	Do not use this product for weapons or other military purposes.
<b>NOTICE</b>	Please note that the product name, specifications, appearance, etc., of the product listed in this manual may be changed without notice in order to improve quality.
<b>NOTICE</b>	Do not use this product for applications where it is expected to cause serious damage to life, body, or property, such as medical equipment or safety devices.



## 2.2. Disposal Precautions

When disposing of this product, please have it properly disposed of by a specialized industrial waste disposal company.

## 2.3. Storage and Transportation Precautions

1) Do not store this product in the following environments or conditions as it may impair performance or connector mating performance.

- ① Storage in places with high concentrations of corrosive gases such as sea breeze, Cl<sub>2</sub>, H<sub>2</sub>S, NH<sub>3</sub>, S, SO<sub>2</sub>, NO<sub>2</sub>, etc.
- ② Storage outside the recommended temperature and humidity range.
- ③ Storage in direct sunlight or in places where condensation may occur.
- ④ Storage in places where strong static electricity is generated.

2) When transporting and storing this product, handle the packaging box with the correct orientation (with "ASTER" indicated on the packaging box facing upward). If the packaging box is dropped with the top side down, excessive force may be applied to the product, causing damage such as bent terminals.

## 3. Warranty

The warranty period for this product is one year from the date of delivery to the customer by our company.

## 4. Typical Characteristics

This chapter describes the electrical characteristics. Although the characteristics are controlled by software, this manual describes the basic characteristics.

### 4.1. Absolute Maximum Ratings

Table 4.1 Absolute Maximum Ratings (Reference)

Item	Symbol	Min	Max	Unit
Battery Voltage	Vbat	-0.3	60	V
Drain Current (AC U, V, W phase) at 25°C	I <sub>ph_U, V, W</sub>	-	60	A <sub>p-p</sub>
Drain Current (Pulse U, V, W phase) t=100us	I <sub>dp</sub>	-	120	A <sub>p-p</sub>
Maximum Potential Difference (between CANH and CANL)	V <sub>diff</sub>	-58	58	V
Storage Temperature	T <sub>stg</sub>	-20	85	°C

\* Measurement Environment: 20°C

\* Absolute maximum ratings are the limits that should never be exceeded, even momentarily. Exceeding any single rating can lead to device destruction or degradation, resulting in hazards such as explosion or combustion. Therefore, it is essential to configure the application equipment to ensure that absolute maximum ratings (current, voltage, power consumption, temperature) are not exceeded.



## 4.2. Recommended Operating Conditions

**Table 4.2 Recommended Operating Conditions**

Item	Symbol	Min	Standard	Max	Unit
Battery voltage	Vbat	38.4	44.4	50.4	V
Recommended replacement time	–	–	–	500	H
Operating ambient temperature	Topr	–10		45	°C

※The recommended replacement time may vary depending on the results of reliability assessments and maintenance history.

※The operating ambient temperature is assumed to be within the environmental conditions of Japan.

※Reference propeller size: FA28.2 × 9.2

## 4.3. DC Electrical Characteristics

※These specifications may change depending on the selected IC. Changes to some ICs may result in changes to the specifications.

**Table 4.3.1 DC Electrical Characteristics (MCU Basic Characteristics) (Reference Values)**

	Item	Symbol	Condition	Min	Avg.	Max	Unit
MCU	Supply Voltage	VDD	fOSC = 8 ~ 10 MHz fsys = 1 ~ 80 MHz	4.5	–	5.5	V
	Low-level Input Voltage	Schmitt Trigger Input VIL1	VDD = 4.5V ~ 5.5V	–0.3	–	0.25*VDD	V
	High-level Input Voltage	Schmitt Trigger Input VIH1	VDD = 4.5V ~ 5.5V	0.75*VDD	–	VDD	V
	Low-level Output Voltage	VOL	IOL = 1.6 mA	–	–	0.4	V
	High-level Output Voltage	VOH	IOH = –1.6 mA	4.1	–	–	V
	Input Leakage Current	ILI1	0.0 ≤ VIN ≤ VDD	–	0.02	±5	μA
	Output Leakage Current	ILO	0.2 ≤ VIN ≤ VDD – 0.2	–	0.05	±10	μA
	Input Control Frequency	Fcont		10	–	1000	Hz
	Schmitt Trigger Hysteresis	VTH	4.5 ≤ VDD ≤ 5.5	0.3	0.6	–	V
	Pin Capacitance	CIO	fc=1MHz	–	–	10	pF

**Table 4.3.2 DC Electrical Characteristics (Pre-driver Basic Characteristics) (Reference Values)**

	Item	Symbol	Condition	Min	Avg.	Max	Unit
プリドライバ	Supply Voltage	VDD	–	4.4	–	60	V
	High-Side Voltage	VHB	–	–10		120	V
	Operating Current	IPVDD_OP	EN_GATE = enabled; LDO reg = no load		10		mA
	Gate Drive Frequency	Fgate		10	–	50	KHz
	Low-Side Gate Current	VLOH			2.5		A
	High-Side Gate Current	VHOL			2.5		A

※The gate drive frequency is set automatically within the system based on the motor's characteristics.

#### 4.4. A/D Converter Characteristics

This product features a built-in 12-bit ADC within the MCU and an operational amplifier on the pre-driver side.

**Table 4.4.1 Digital-to-Analog Converter (DAC) Characteristics (Control Board MCU) (Reference Values)**

Item	Condition	Min	Avg.	Max	Unit
Analog Reference Voltage	–	–	5.05	–	V
Analog Input Voltage	–	0	–	5.05	V
Current Consumption	–	–	3.5	5	mA
Integral Nonlinearity Error	AIN load resistance $\leq 600 \Omega$ AIN load capacitance $\geq 0.1 \mu F$ conversion time $\geq 2 \mu s$	–6	–	6	LSB
Differential Nonlinearity Error		–5	–	5	
Offset Error		–5	–	5	
Full Scale Error		–6	–	6	

**Table 4.4.2 Analog-to-Digital Converter (ADC) Characteristics (Three-Phase Output Board Pre-driver) (Reference Values)**

Item	Condition	Min	Avg.	Max	Unit
Current sense gain	GAIN_CSx=00		10		V/V
Current sense gain error	Input differential $> 0.025 V$	–3		3	%
Current sense timing setting	GCSA = 10; Vstep = 0.46 V		300		ns
DC offset voltage	GCSA = 10; input shorted; RTI	–4		4	mV
Input offset error	GCSA = 10; input shorted; RTI		10		$\mu V/C$
Input bias current	VIN_COM = 0; SOx open			100	$\mu A$
Input bias current offset	IBIAS (SNx-SPx); VIN_COM = 0; Sox open		1		$\mu A$

#### 4.5. Protection Functions

This product is equipped with various hardware-based fault detection and protection functions. An audible notification function is provided, which vibrates the motor within the audible frequency range to simply notify the ESC status.

**Table 4.5 List of Protection Functions**

Item	Content	Protection Action
Battery Under-voltage Protection	$V_{BAT} \leq 18V$	Error signal output
Battery Over-voltage Detection	$V_{BAT} \geq 58V$	Error signal output
Short Circuit Protection	$V_{BAT} \leq 0.5V$	Stop operation
Overcurrent Protection	70A	Error signal output
DC/DC Converter Output Voltage Abnormal Detection	$5.05V \pm 10\%$	Error signal output, Stop operation
Analog Voltage Under-voltage Protection	$AVDD = 3.3 \sim 3.5V$ or below	Error signal output
Abnormal Temperature Detection	Pre-driver IC abnormal temperature $140^{\circ}C$	Error signal output
Abnormal Temperature Protection	Pre-driver IC limit temperature $175^{\circ}C$	Stop operation
Slip Detection	Automatic recovery from slip, error output if unable to recover	Error signal output

※Automatic recovery from slip requires the motor to be self-rotating after a slip occurs and does not guarantee recovery from all slip conditions.

**Table 4.6 List of Voice Notification Functions**

Notification Content		Notification Sound
Battery Voltage	Normal	1-cell sound 277.183Hz 50ms_ON 50ms_OFF 2-cell sound 293.665Hz 50ms_ON 50ms_OFF 3-cell sound 311.127Hz 50ms_ON 50ms_OFF 4-cell sound 329.628Hz 50ms_ON 50ms_OFF 5-cell sound 261.626Hz 200ms_ON 50ms_OFF
	Abnormal	No sound
Flight Ready Recognition		261.626Hz 150ms_ON 329.628Hz 150ms_ON 391.955Hz 150ms_ON (in sequence)
System Abnormal		523.251Hz 100ms_ON 100ms_OFF, repeated
No Control Signal		523.251Hz 2000ms_ON 1000ms_OF, repeated

A voice notification will be played within 3 seconds after power-on.

The notification order is as follows

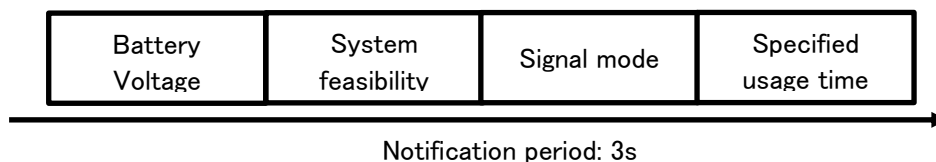

**Table 4.7 Battery voltage notification number**

Battery voltage	通知パターン
18	5-cell sound to 1-cell sound
20	5-cell sound to 1-cell sound
24	5-cell sound to 1-cell sound to 2-cell sound
48	5-cell sound to 5-cell sound to 2-cell sound



## 5. System Overview

In this chapter, we will explain the overall system configuration and provide an outline of each circuit board.

### 5.1. ESC Connection Diagram (PWM Control)

When controlling motor speed using PWM, connect one PWM signal to each ESC.

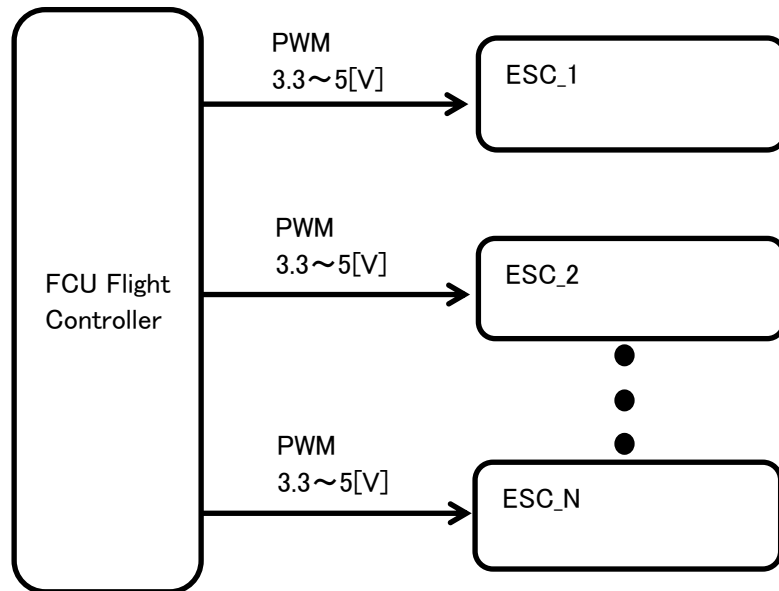

Figure 5.2 ESC Connection Diagram (PWM Control)

## 5.2. ESC Connection Diagram (CAN Control)

When controlling motor speed via CAN communication, please attach a 120Ω termination resistor between CAN\_H and CAN\_L. The ESC does not include a termination resistor.

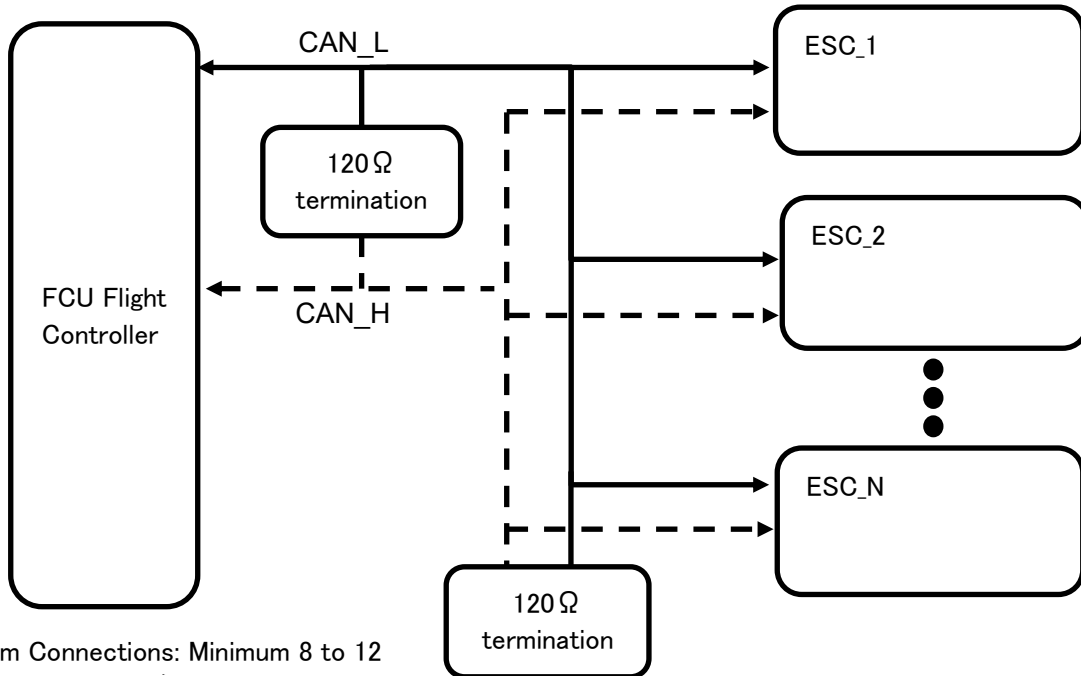

Figure 5.3 ESC Connection Diagram (CAN Bus Control)

※If you plan to use CAN communication, please contact Aster Corporation separately.

## 5.3. Control Board Overview

- Uses an ARM Cortex-M4 core from ARM
- Vector engine  
Calculation function for motor control
- RAM: 34Kbyte (MCU)
- FLASHROM: 256Kbyte(MCU)
- EEPROM: 256Kbyte
- Debug PORT: UART, JTAG, CAN
- Control PWM input: 400Hz (changeable within the maximum frequency of 1KHz)
- CAN communication: Maximum transfer rate 1Mbps

## 5.4. Three-Phase Output Board Overview

- Power MOSFET
- Current detection resistor: 3 shunt
- Temperature monitoring component: Power MOSFET
- Gate driver: Charge pump type
- Gate drive frequency: 30KHz

## 5.5. Additional Information on PWM Signal

The current requirement specifies the PWM signal as follows.

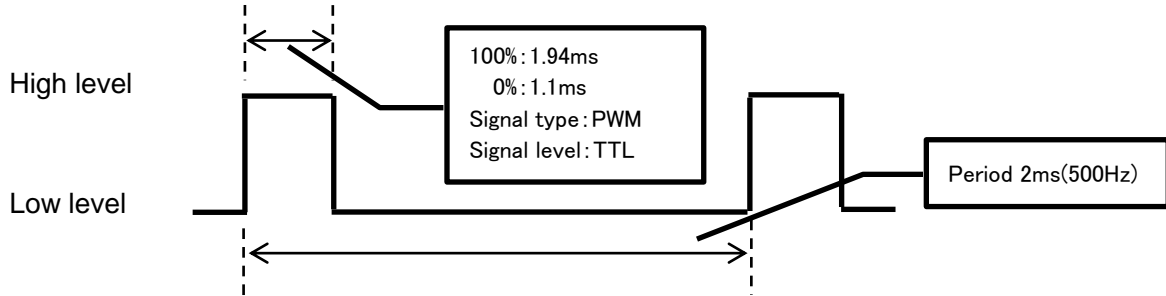

## 5.6. Input Capacitor Capacitance

The input capacitor capacitance of this product is designed based on the input cable length, but since the wiring length varies depending on each user's situation, it is important to have an optimal capacitor capacitance for stable operation. Please refer to the recommended capacitor capacitance table below and adjust the capacitor capacitance according to your application.

**Table 5.1 Connector for communication with control equipment**

Cable length[m]	Capacitor capacitance[uF]
0.5	100
1	220
2	470

※Assuming AWG14 cable size. For smaller cable sizes, additional capacitance may be required.

## 6. Interface Assignment

In this chapter, we will explain the external communication interfaces of the ESC.

### 6.1. External Interface Assignment

The pin assignment of the control signal connector is shown below.

**Table 6.1 Connector for communication with control equipment**

Terminal No.	Signal Name	Function	Attached Cable Marking
1	PWM input	PWM control signal	Red
2	GND	GND	None
3	GND	GND	Unused
4	CAN_H	CAN communication signal	
5	CAN_L	CAN communication signal	
6	POWER(5V)	5[V] output power	

※For CAN communication, please contact Aster Corporation separately.

## 7. Power Cable Assignment

本 In this chapter, we will explain the connector assignment for the power supply.

### 7.1. Three-Phase Output Board Lead Wire Assignment

Table 7.1 Pin Assignment for Motor Connection Wires (CW)

Terminal No.	Signal Name	Function
1	W_Phase (Black wire)	W phase output signal
2	V_Phase (Black wire)	V phase output signal
3	U_Phase (Black wire)	U phase output signal

Table 7.2 Battery connection wire pin assignment

Terminal No.	Signal Name	Function
1	POWER (Red wire)	Battery power supply
3	GND (Black wire)	GND

## 8. Dimensional Drawing

In this chapter, we will describe the overall external dimensions of the completed product.

### 8.1. Overall External Dimensions of the Completed Product

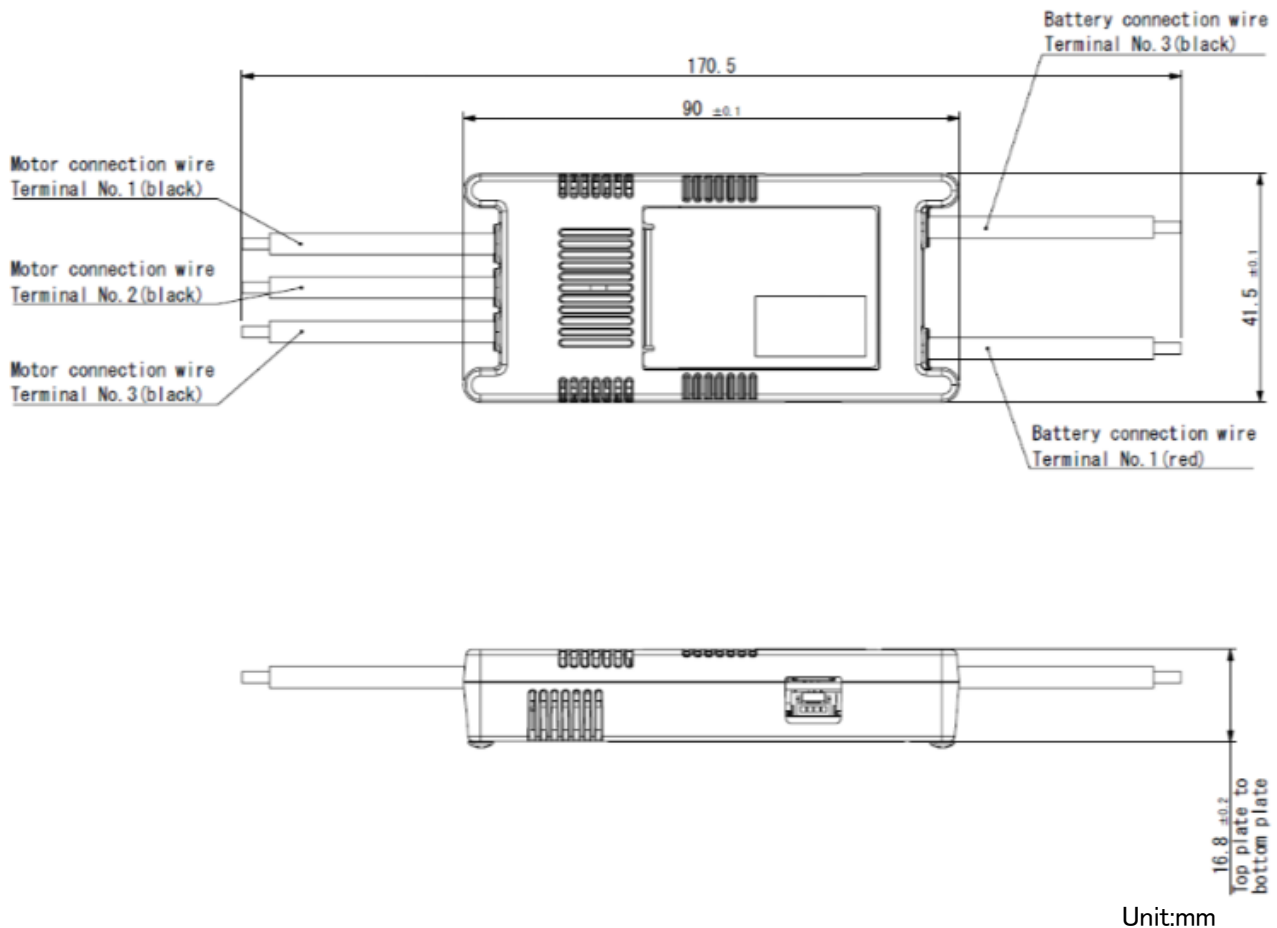

Figure 8.1 Overall external dimensions of the completed product



Revision history

Ver	Date of Issue	Revision History
1.0	1/AUG/2024	Initial Release



Note



Note

Manufacturer: Aster Co., Ltd.

Address: 12-3 Yanagida, Yokote City, Akita Prefecture 013-0054, Japan