



Motor User Manual

MODEL NAME : TK3-A

Ver.1.0



Contents

1. Introduction	3
2. Safety Precautions	3
2.1. Precautions for Use	3
2.2. Disposal Precautions	5
2.3. Storage and Transportation Precautions	5
3. Warranty	5
1. Typical Characteristics	6
1.1. Structure	6
1.2. Rated conditions	6
1.3. Maximum operating conditions	6
1.4. Environmental conditions	6
1.5. Initial characteristics	7
1.6. Mechanical properties	7
1.7. Measurement	7
2. Interface	8
2.1. Assignment of Three-Phase Input for Motor Connection Wires	8
2.2. Input Signal	8
3. Dimensions	8
3.1. Overall Dimensions of the Finished Product	8





1. Introduction





This manual is for the three-phase brushless motor (hereinafter referred to as the “motor”).

2. Safety Precautions

The motor described in this manual should be used at the customer’s discretion. Our company shall not be held responsible for any harm or damage caused by its use. The following content is important for preventing harm to users and others, as well as damage to property, and for ensuring the safe and correct use of the product. Please read the following carefully before reading the main text and follow the instructions.

Symbol	Explanation
 WARNING	Indicates that the user may be killed or seriously injured if handled incorrectly.
 CAUTION	Indicates that the user may suffer minor injuries or that property damage may occur if handled incorrectly.
NOTICE	Indicates a note.

2.1. Precautions for Use

Precautions	
 WARNING	Do not store or use this product in an area where explosive gases or dust may be generated. This may cause an explosion.
 WARNING	Do not use this product in a radiation environment. This product is not radiation-resistant.
 CAUTION	Contacting the power terminals with your fingers or metal objects may result in electric shock or burns due to abnormal heat generation. Avoid unnecessary contact with the power terminals.
 CAUTION	If the unit becomes abnormally hot, stop using it immediately. After stopping, confirm that the abnormal heat has subsided. There is a risk of burns.
NOTICE	Do not disassemble, repair, or modify this unit. This may cause malfunctions or damage.
NOTICE	Please confirm that there are no foreign objects on the mounting surface or inside the screw when connecting the terminal. Loose screws or poor contact may occur.
NOTICE	Please be careful not to overtighten the screws. This may cause damage.



NOTICE	Please ensure that there is sufficient slack in the wiring when connecting. This may cause damage.
NOTICE	If you come into contact with any metal parts and experience any discomfort, stop using the product immediately and consult a medical professional.
NOTICE	Be careful not to allow oil, solvents, or other substances to come into contact with the product. This may cause the housing to deform or crack.
NOTICE	If the product becomes dirty, please be careful to wipe it clean without applying excessive force. Excessive cleaning may cause damage or discoloration of the housing. It is recommended to clean the product when it becomes dirty.
NOTICE	Do not handle the Motor by the cable only.
NOTICE	Do not insert or remove the lead wires while the product is powered.
NOTICE	Do not drop or strike the Motor forcefully. Even if there is no initial malfunction, we cannot guarantee the product warranty.
NOTICE	Please confirm the suitability for actual use in a driver-mounted state by yourself.
NOTICE	Beware of corrosive gases. This may cause rusting of metal parts and chemical effects on grease.
NOTICE	Please note that this motor does not have any built-in protection circuits against overvoltage, overtemperature, external noise, etc.
NOTICE	We do not guarantee the quality of the product after disassembly and reassembly.
NOTICE	Operators who handle the Motor directly and equipment that comes into contact with the Motor should take measures to prevent static electricity and leakage.
NOTICE	We cannot guarantee any patent issues other than the Motor. Please conduct a thorough investigation and use the product at your own risk.
NOTICE	Do not use this product for weapons or other military purposes.
NOTICE	Please note that the product name, specifications, appearance, etc., of the product listed in this manual may be changed without notice in order to improve quality.
NOTICE	Do not use this product for applications where it is expected to cause serious damage to life, body, or property, such as medical equipment or safety devices.



2.2. Disposal Precautions

When disposing of this product, please have it properly disposed of by a specialized industrial waste disposal company.

2.3. Storage and Transportation Precautions

1) Do not store this product in the following environments or conditions as it may impair performance or connector mating performance.

- ① Storage in places with high concentrations of corrosive gases such as sea breeze, Cl₂, H₂S, NH₃, S, SO₂, NO₂, etc.
- ② Storage outside the recommended temperature and humidity range.
- ③ Storage in direct sunlight or in places where condensation may occur.
- ④ Storage in places where strong static electricity is generated.

2) When transporting and storing this product, handle the packaging box with the correct orientation (with "ASTER" indicated on the packaging box facing upward). If the packaging box is dropped with the top side down, excessive force may be applied to the product, causing damage such as bent terminals.

3. Warranty

The warranty period for this product is one year from the date of delivery to the customer by our company.



1. Typical Characteristics

In this chapter, we will describe the motor structure and basic characteristics.

1.1. Structure

Table 1 Structure

No.	Item	Specification	Remarks
1	Motor Type	Permanent Magnet Synchronous Motor	Inner Rotor

1.2. Rated conditions

Table 2 Rated conditions

No.	Item	Unit	Specification	Remarks
1	KV Value	–	185±10%	Design value
2	Rotation Direction	–	CW/CCW	As seen from the output shaft
3	Continuous Rated Voltage	V	24	–
4	Continuous Rated Output	W	490	@2900[min^{-1}], @10 [min])
5	Maximum Rated Output	W	640	@10 [min]
6	Maximum Rated Torque	N·m	1.88	@10 [min] ※27.6[Arms] per phase
7	Maximum Rated Speed	min^{-1}	3250	@10 [min]

* Measurement by our standard ESC

* Measurement Environment: 20°C

* Absolute maximum ratings are the limits that should never be exceeded, even momentarily. Exceeding any single rating can lead to device destruction or degradation, resulting in hazards such as explosion or combustion. Therefore, it is essential to configure the application equipment to ensure that absolute maximum ratings (current, voltage, power consumption, temperature) are not exceeded.

1.3. Maximum operating conditions

Table 3 Maximum operating conditions

No.	Item	Unit	Specification	Remarks
1	Maximum voltage	V	28.8	
2	Maximum load torque	N·m	2.1	@10[sec]
3	Maximum rotational speed	min^{-1}	3500	No load

1.4. Environmental conditions

Table 4 Environmental conditions

No.	Operating temperature	Unit	Specification	Remarks
1	Operating temperature	°C	-20~+40	
2	Storage temperature	°C	-25~+40	No condensation
3	Storage humidity	%Rh	20~80	No condensation

1.5. Initial characteristics

Table 5 Initial characteristics

No.	Operating temperature	Unit	Specification	Remarks
1	Insulation resistance	mA	1.0 or less	AC500[V],60[sec] @ between lead wires and housing
2	Phase resistance	mΩ	26.5±5%	

1.6. Mechanical properties

Table 6 Mechanical properties

No.	Operating temperature	Unit	Specification	Remarks
1	Weight	g	324	Nominal value

1.7. Measurement

This data is for reference only and is not guaranteed.

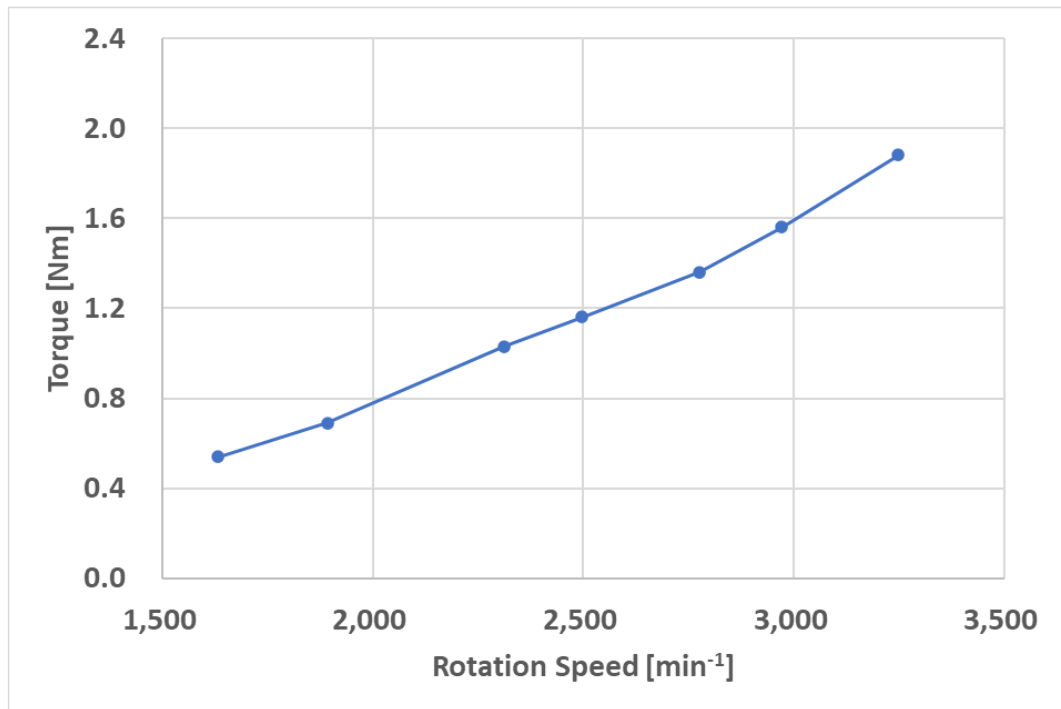

Figure 1 NT characteristics



2. Interface

In this chapter, we will explain the assignment of motor connection wires.

2.1. Assignment of Three-Phase Input for Motor Connection Wires

Table 7 Assignment of Three-Phase Input for Motor Connection Wires

No.	Item	Function
1	W-phase	W-phase input
2	V-phase	V-phase input
3	U-phase	U-phase input

2.2. Input Signal

This motor is designed to maximize performance when operated with sensorless 180° conduction and Field Oriented Control (FOC) using our ESC.

While 120° conduction sensorless operation is possible, performance parameters such as torque, rotational speed, and efficiency may be lower compared to 180° conduction FOC control.

3. Dimensions

This chapter describes the dimensions of the housing.

3.1. Overall Dimensions of the Finished Product

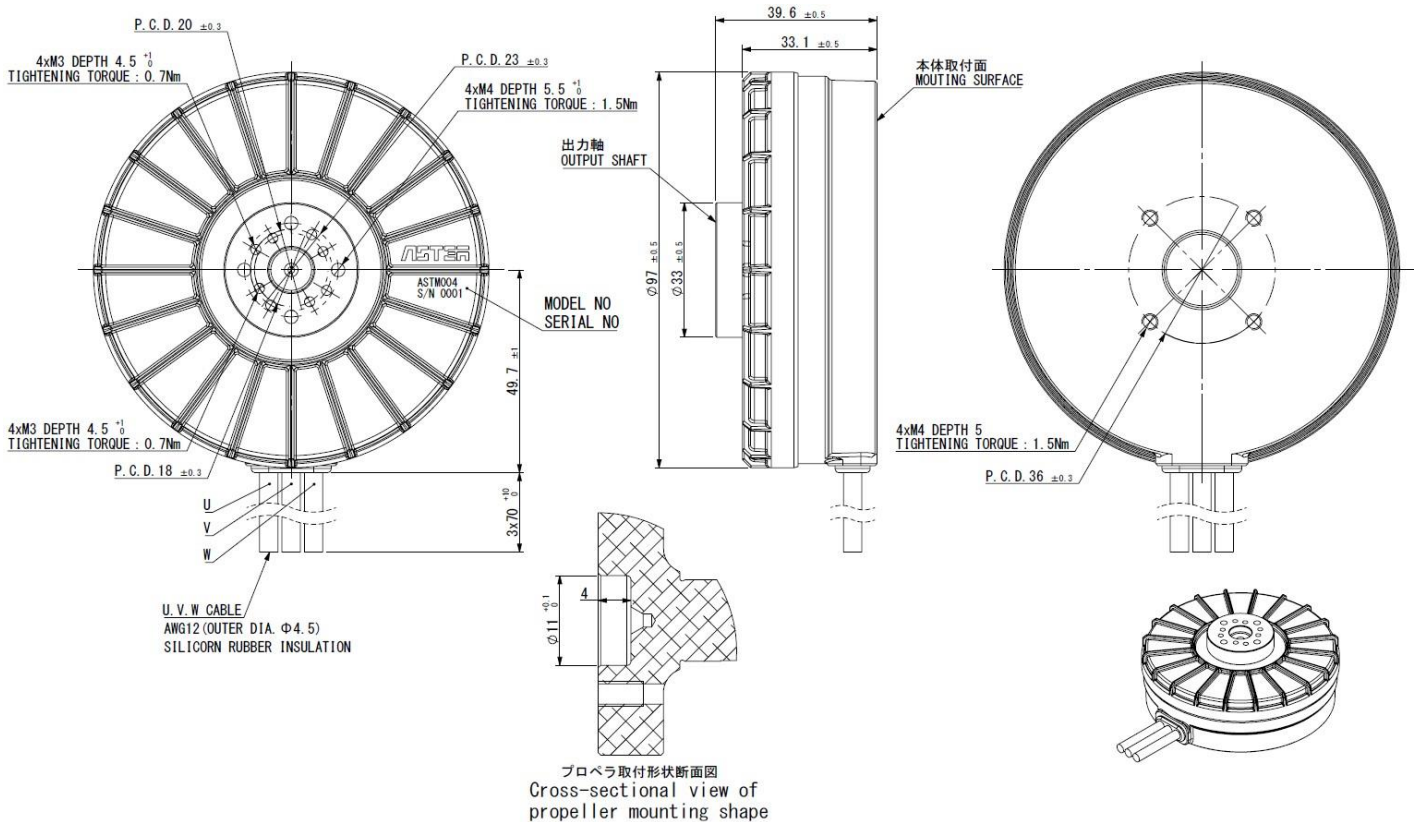

Unit:mm



Revision history

Ver	Date of Issue	Revision History
1.0	1/AUG/2024	Initial Release



メモ



メモ

製造元
株式会社アスター
〒013-0054 秋田県横手市柳田 12-3